



EMProbe

V01.022020

Accurate and Repeatable High-Resolution EMC and EMI diagnostics with Hand-held Near Field Probes on your lab-bench

3D Precision Technology used to assist high density board designers to use off the shelf hand-held probes and visualise the root causes of potential EMC and EMI problems during pre/post EMC compliance testing.



EMC and signal integrity are major concerns in the design of ultra-high speed (>2 GHz) PCBs. While EMScanner allows designers to easily locate emission by placing the PCB on its flat surface, the EMProbe allows users to test the component side of the PCB and adjust the height of the scan.

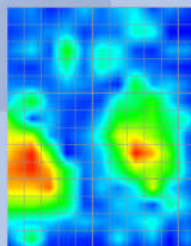

This enables the design engineers to diagnose EMC/EMI problems, limited only by the choice of the Spectrum Analyser and the Near Field Probe, and allows them to visualize the root causes of potential EMC and EMI problems in/on/off a non-flat surface or the complete product.



EMProbe extension – X Axis increase reach to 900mm.



During any new product development process, design engineers must find, characterize and address unintended radiators or RF leakage to pass compliance testing. EMProbe allows board designers to pre-test and resolve EMC and EMI problems early on, thus avoiding unexpected EMC compliance test results.

EMProbe delivers **repeatable** and **reliable** results that pinpoint, in less than a second, the cause of a design failure. As a result, the user can personally test the design without having to rely on another department, test engineer, or time-consuming off-site testing. After diagnosing even an intermittent problem, the engineer can implement a design change and retest. The results provide concrete verification of the effectiveness (or not) of the design change.

The EMProbe solution consists of a computer controlled Robotic Arm, Near Field probe and a customer supplied Spectrum Analyser, all controlled by the EMViewer software.

The EMProbe diagnostic capabilities allow design teams to **reduce testing time** by more than two orders of magnitude. Users have also documented fifty percent reductions in design cycle times. This allows the design team to immediately analyse and compare design iterations.

Ideal projects for the EMProbe are components side testing of boards designed for high speed, high power, and/or high density/complexity. Any PCB that places a premium on board real estate also qualifies as an excellent candidate.

The EMProbe provides an **easy-to-use, cost-effective and scalable solution** for design teams. Emission, immunity, filtering, EMI shielding, broadband noise and Common Mode testing are some of the applications that the EMProbe system addresses in mere seconds.

EMProbe

Features

Capability	Spectral scan, spatial scan, peak-hold, continuous scanning, spectral and spatial comparison, scripting, limit lines and report generation.
Spatial scan time	Continuous real-time or sub-second single scan for entire scan area Dependent on spectrum analyser performance.
Spectral scan time	45 seconds for L 10 cm x W 10 cm (L 4" x W 4") PCB with a 100 MHz span and 100 kHz RBW. Scanning area, span and RBW are user selectable within spectrum analyser specifications
Supported spectrum analysers	Wide range of Keysight and Rohde & Schwarz Spectrum Analysers are supported. Check www.yictechnologies.com for details.
Supported operating systems	Windows 10®
Supported CAD overlays	Standard Gerber© RS274x format and HPGL format



Workspace

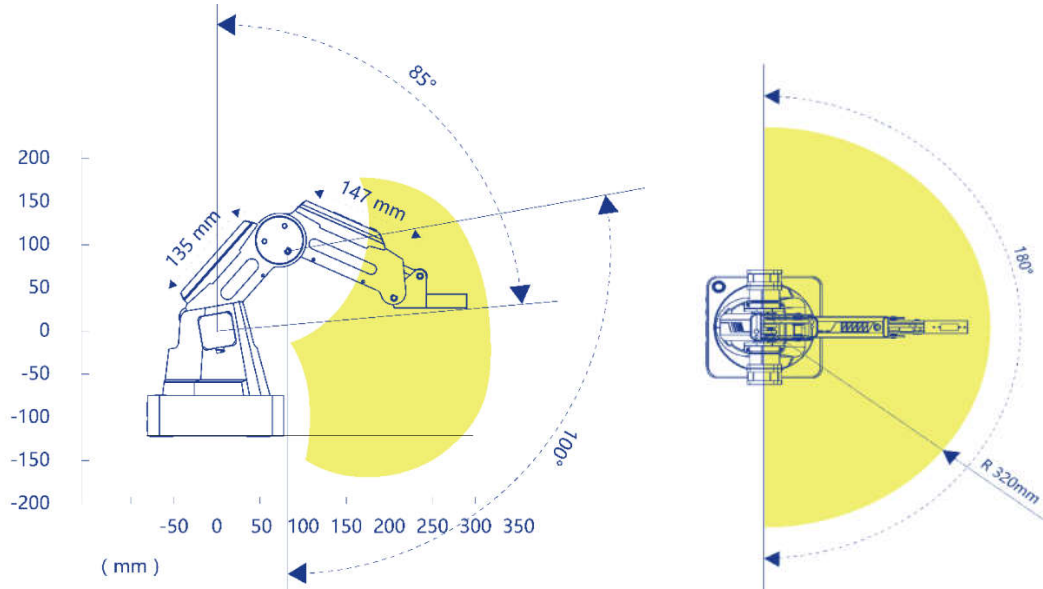

Probes

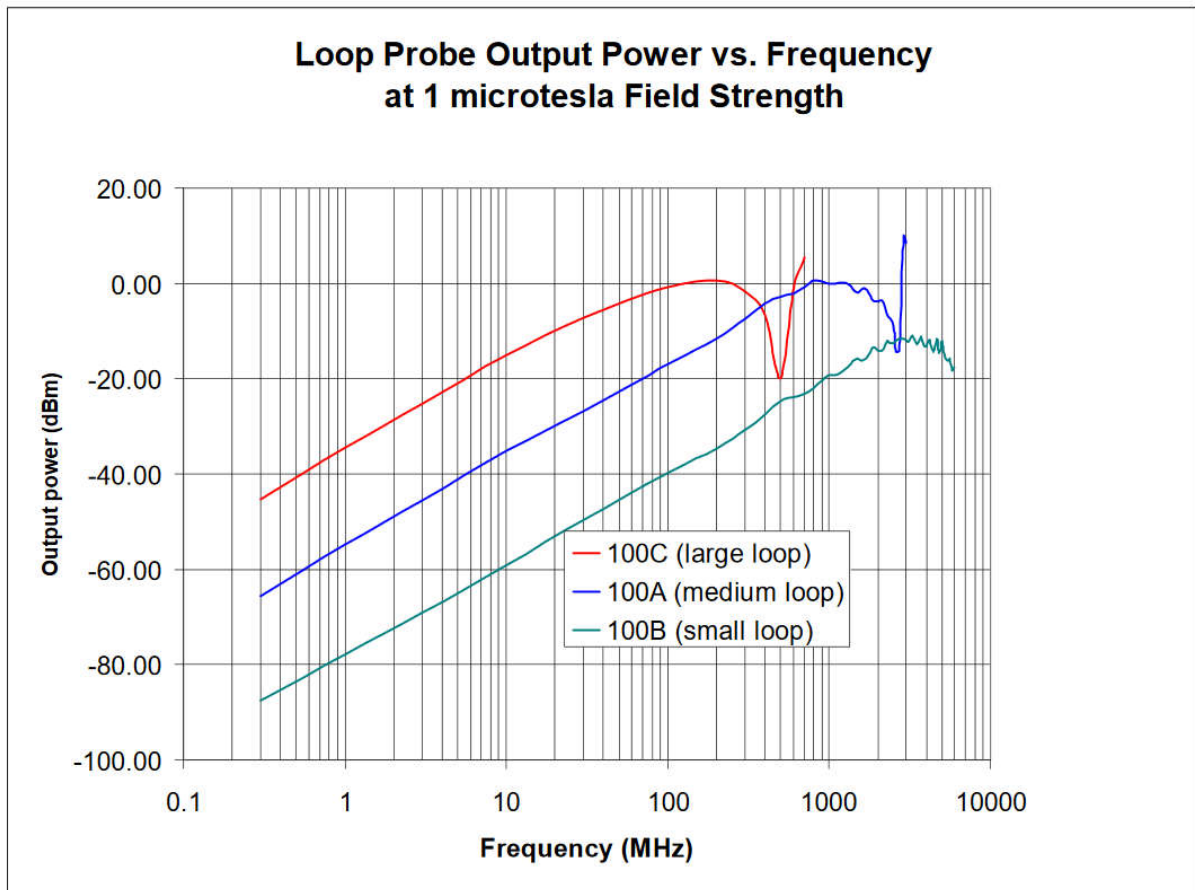



Specifications

Broadband frequency coverage	Dependent on spectrum analyser and the probe performance
Measurement sensitivity	Dependent on spectrum analyser and the probe performance
Spatial resolution	Base version 7.5 mm, High Resolution 0.4 mm
Scan area	300 mm Radius
Scan Height (Max)	150 mm Radius
Frequency accuracy of peaks	Peak marking accuracy of spectrum analyser
Probe to probe uniformity	Dependent on the selected probe
Maximum radiated power load	Dependent on spectrum analyser and the probe performance
Operating temperature	From 15° C to 40° C (continuous spectral and spatial scans at 50 MHz)
NET Weight	3.40 Kg (excluding cables and the adaptor)

Y.I.C. Technologies Ltd

www.yictechnologies.com
support@yictechnologies.com